



limp
12.5kA

DC Power Surge Protector for Photovoltaic Applications

DS60VGPV-500, DS60VGPV-1000



DS60VGPV-1000



DS60VGPV is a heavy duty DC Surge Protection Device (SPD) for high risk, low tolerance DC power applications up to 1200Vdc. The DS60VGPV provides protection against the direct and indirect effects of lightning and has a unique no leakage current design.

CITEL's patented hybrid Metal Oxide Varistor (MOV)/Gas-filled Spark Gap (GSG) protection circuit will dramatically increase the life expectancy of the surge protector and leave no footprint within the DC power system.

The DS60VGPV is a multi-pole monoblock base protecting both positive and negative to ground. It is installed in parallel with the power system and is mounted on a din rail for convenient application directly inside an Inverter or DC combiner box.

The DS60VGPV incorporates replaceable protection modules with specific DC thermal fuses that allow for high surge current handling (12.5kA 10/350us), reliable disconnection and produce no follow on current. These units have visual fault indicators and remote signalization for real-time status indication.



Available Options

- Polycarbonate Enclosure, NEMA 4X
Part# CDS60VGPV-xxx
- 40A Fused Disconnect
Part# CDS60VGPV-xxx-40

Dimensions and Diagram (in mm)

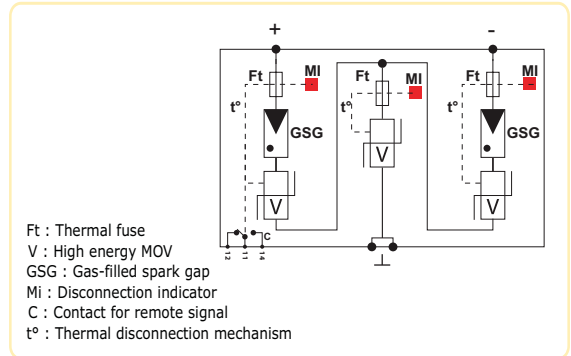
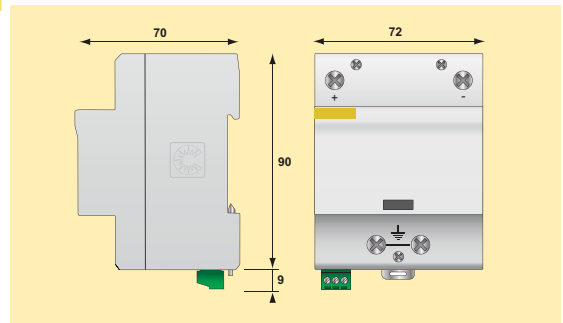

Characteristics

CITEL Part Number	DS60VGPV-500	DS60VGPV-1000
Network voltage (Un) dc	500 Vdc	1000 Vdc
Protection mode	MC/MD ¹	MC/MD ¹
Max. Operating Voltage (Uc) dc	600 Vdc	1200 Vdc
IEC/UL Nominal discharge current (In) 15 x 8/20 μs impulses	20 kA	20 kA
Maximum discharge current (Iimp) Max. 10/350 μs	12.5 kA	12.5 kA
Max. Lightning current by pole (Imax) Max. 8/20 μs	40 kA	40 kA
Protection level (at In) (Up)	<1.7 kV	<2.8 kV
Residual voltage at 5 kA (Up)	<1.4 kV	<2.3 kV
Operating current (Ic) Leakage Current at Uc	none	Very Important
Follow current (If)	none	
Thermal Disconnector	Internal	
Dimensions	see diagram	
Connection	by screw terminals : #4 AWG MAX	
Disconnection indicator	1 mechanical indicator	
Remote signaling	250V/0.5 (AC) - 125V/3A (DC)	
Mounting	symmetrical rail 35 mm	
Operating temperature	-50/+85 °C	
Protection class	IP20	
Housing material	Thermoplastic UL94-V0	
Standards compliance		
NF EN 61643-11	France	Parafoudre Basse Tension - Essais Classe II
IEC 61643-1	Intl	Low Voltage SPD - Type I and II
CSA C22.2	Canada	Class 90941 32
UL1449 3rd Ed. for PV	USA	Type 4, Type 1 Location
DIN EN 61643-11	Ger	Surge Arrester Type I and II

Note 1 MC = Common Mode (+/PE or -/PE) and MC/MD = Common Mode and Differential Mode (+/-)